

Climbing Jack Procedure

A climbing jack is a specially constructed hydraulic jack with a plunger that is used upside-down. The plunger can move in and out at the bottom of the climbing jack. The jack casing pushes the load upward or lowers the load downward. The jacks are shipped fully assembled.

Note: Lift the climbing jacks only from the supplied top lifting plate using suitable shackles or hooks in the lifting holes or by forklift under the lifting plate.

Setup

To set up for jacking:

- Ensure that the areas under the load's lifting points are appropriate. They must be at the same elevation, flat, level and able to support the jacking loads. It is preferable to start with a full layer of 10 ekki timbers on top of the support surface
- Place the climbing jacks under the load's lifting points and on the support surface
- Connect suitable hydraulic hoses from the power unit to each of the climbing jacks
- Verify that all climbing jacks are placed correctly and verify all hydraulic connections are correct and that the couplers are fully engaged
- Extend the climbing jacks until contact is made with the underside of the load
- Synchronize power unit (see the relevant power unit manual)

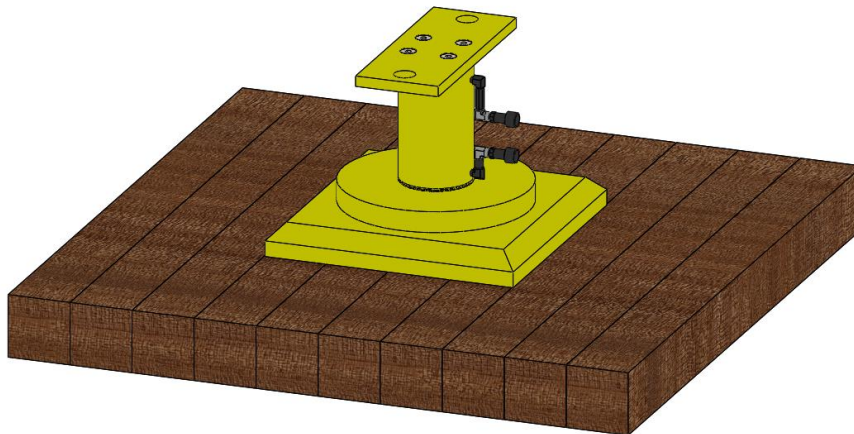

Suggested initial set-up for each jack, with a full layer of 10 ekki timbers

The Blockpile

Caution: It is very important for safety and for proper operation of the climbing jacks that the blockpiles are built correctly and remain straight and stable at all times. Improperly placed timbers may result in instability of the blockpile or interference with the operation of the climbing jack, particularly the plunger foot.

Each layer of timbers (after the first layer of 10) will consist of two stability timbers at the outsides of the blockpile, two timbers under the body of the jack, and a set of centre timbers to support the plunger foot. To fully support the plunger foot, the CJ55 requires two centre timbers, the CJ100 requires three centre timbers, and the CJ200 requires four centre timbers. See below:

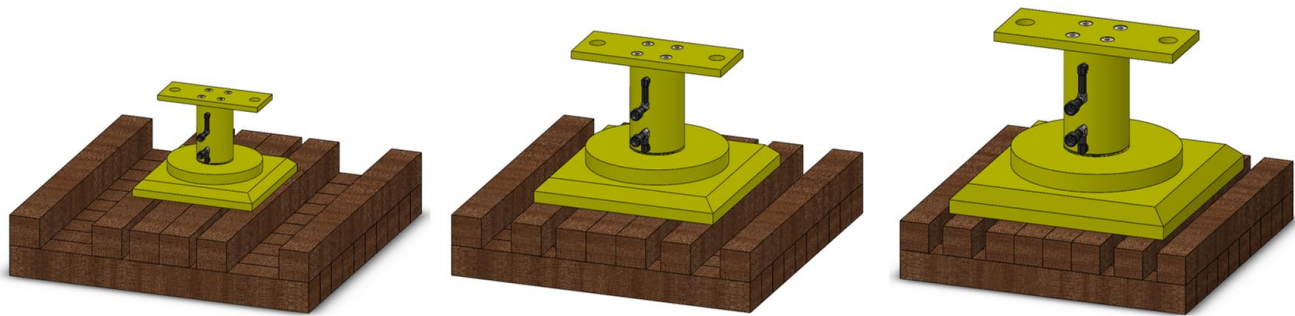

CJ55

CJ100

CJ200

Note: The illustrations below show the CJ55 model; for the CJ100 and CJ200 the same procedure is followed, only being sure to use the appropriate number of centre timbers to fully support the plunger foot, and appropriate timber spacing to support the jack body.

Raising A Load

Once the jacks are set up according to the instructions given in Section 2, the load can be raised by following these steps:

Step 1: Begin to extend the jacks hydraulically; the body of each jack will be raised, along with the load. The load now rests entirely on the plunger foot of each jack and the support surface directly beneath it. Space is created around the plunger on the underside of the jack body.

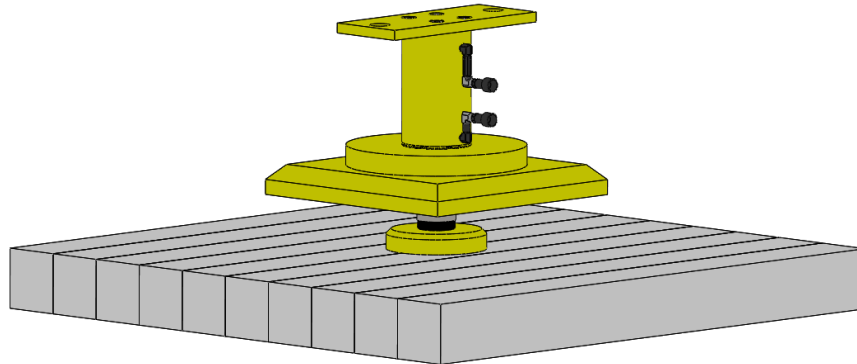

The fully-extended jack is now resting entirely on the plunger foot

Step 2: Once each jack body is sufficiently raised, place timbers and distance strips under the jack body as shown below. If an initial layer of timbers is used as suggested, be sure to place this second layer of timbers perpendicular to the first. Place the stability timbers at the outside of the blockpile as shown.

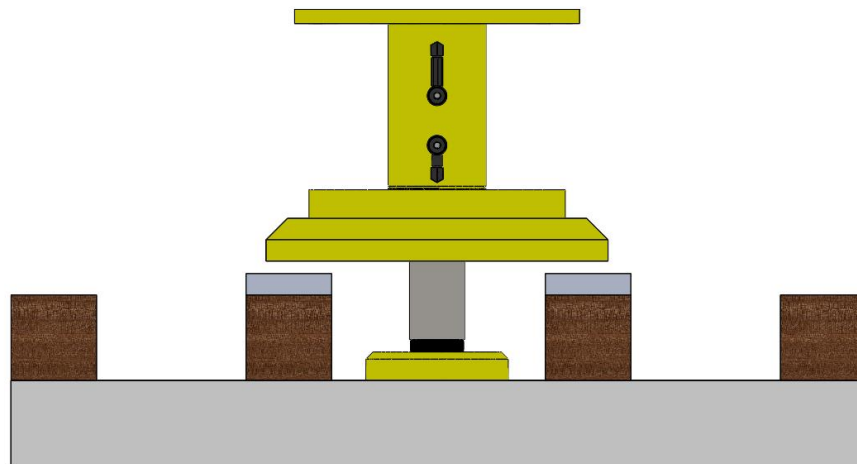

Four timbers are placed perpendicular to the bottom timber layer, with distance strips on the two timbers under the jack body

Step 3: Once the new timbers and distance strips are positioned correctly, retract the plunger to lower the jack body onto the timbers and distance strips.

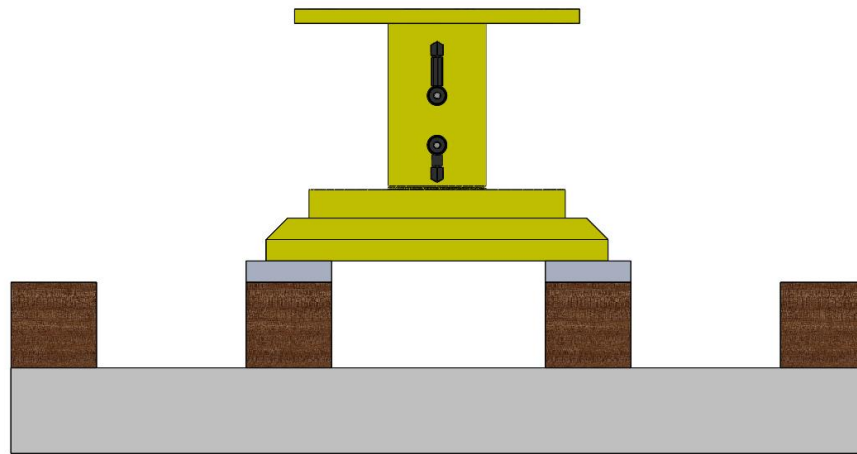

*The plunger is retracted, creating space under the jack;
the jack is now resting entirely on the distance strips*

Step 4: Once the plunger is fully retracted, insert the centre timbers (two for CJ55, three for CJ100, four for CJ200) under the plunger foot as shown below:

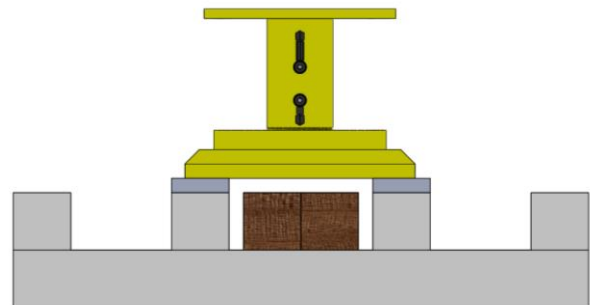
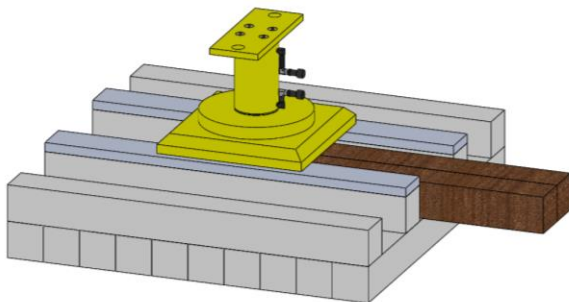

*The centre timbers are placed and aligned under the plunger foot; there is a gap
between these timbers and the timbers currently supporting the jack body*

The load has now been raised by one timber height.

Step 5: Extend the jack fully once more so that the jack and load rest on the centre timbers. Remove the distance strips. A new timber layer can now be constructed perpendicular to the layer beneath it.

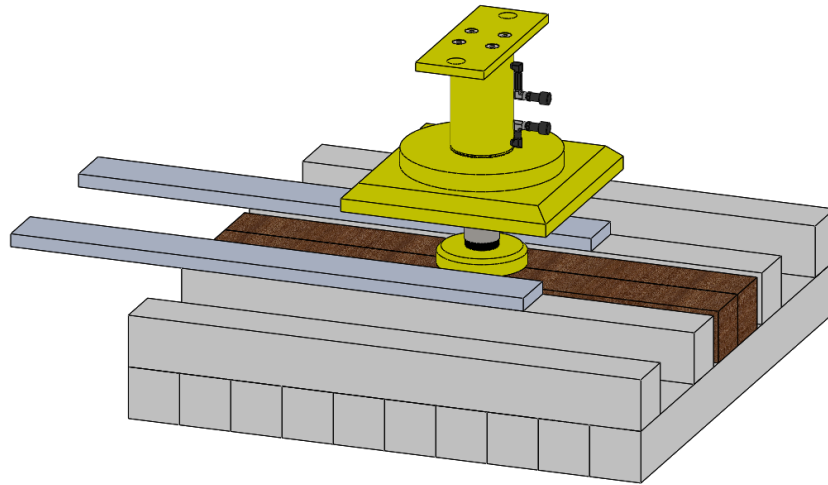

Distance strips are removed, leaving a completed timber layer on top

Repeat Steps 1-5 to continue lifting the load, alternating the direction of the timbers so that each layer is perpendicular to the previous layer, until the desired height is reached. Ensure that all timbers are placed correctly and that each blockpile remains straight and stable as it is built up.

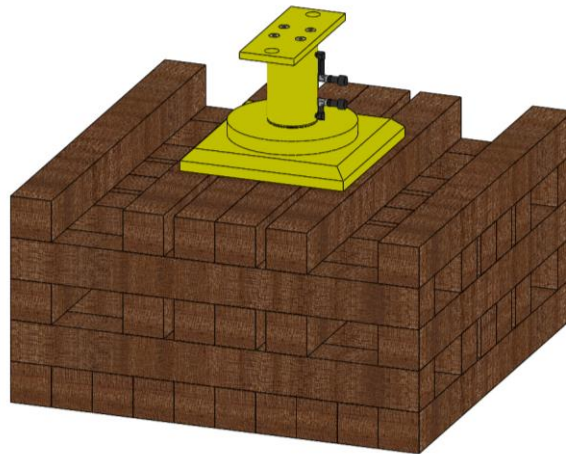

Lowering A Load

To lower a load, simply reverse the steps shown above.

Before lowering, the blockpile should be constructed under the jack body in the same way as when raising the load, alternating the orientation of timbers in each layer so that each layer is perpendicular to those above and below.

Note: It is recommended to build the blockpiles under the climbing jacks one layer at a time, in the same manner as when lifting a load. This procedure will ensure that the timbers are placed correctly.